



**RWANDA  
STANDARD**

**DRS  
424**

Second edition

2025-...-..

---

---

**Furniture — Specifications for bedsteads**

ICS 97.140

---

---

Reference number

DRS 424: 2025

© RSB 2024

In order to match with technological development and to keep continuous progress in industries, standards are subject to periodic review. Users shall ascertain that they are in possession of the latest edition

© RSB 2025

All rights reserved. Unless otherwise specified, no part of this publication may be reproduced or utilized in any form or by any means, electronic or mechanical, including photocopying and microfilm, without prior written permission from RSB.

Requests for permission to reproduce this document should be addressed to:

Rwanda Standards Board

P.O Box 7099 Kigali-Rwanda

KK 15 Rd, 49

Tel. +250 788303492

Toll Free: 3250

E-mail: [info@rsb.gov.rw](mailto:info@rsb.gov.rw)

Website: [www.rsb.gov.rw](http://www.rsb.gov.rw)

ePortal: [www.portal.rsb.gov.rw](http://www.portal.rsb.gov.rw)

# Contents

Page

Foreword .....	iv
1 Scope .....	1
2 Normative references .....	1
3 Terms and definitions .....	1
4 Types .....	2
5 General requirements .....	2
5.1 Materials .....	2
5.1.1 Timber .....	2
5.1.2 Moisture Content .....	2
5.1.3 Defects .....	2
5.1.4 Other Materials .....	2
5.1.5 Adhesives .....	3
5.1.6 Fittings and fasteners .....	3
5.2 Construction .....	3
5.2.1 General .....	3
5.2.2 Joints .....	3
5.3 Dimensions and sizes .....	3
5.4 Workmanship and finishing .....	4
6 Requirements for strength and durability .....	5
6.1 General .....	5
6.2 Test procedures for strength and durability .....	5
7 Marking .....	5
8 Packing for transportation .....	5

Copy for public comments only

## **Foreword**

Rwanda Standards are prepared by Technical Committees and approved by Rwanda Standards Board (RSB) Board of Directors in accordance with the procedures of RSB, in compliance with Annex 3 of the WTO/TBT agreement on the preparation, adoption and application of standards.

The main task of technical committees is to prepare national standards. Final Draft Rwanda Standards adopted by Technical committees are ratified by members of RSB Board of Directors for publication and gazettment as Rwanda Standards.

RS 424 was prepared by Technical Committee RSB/TC 54, *Timber, furniture and engineered wood*.

This second edition cancels and replaces the first edition (RS 424: 2020), [clause 6] of which has been technically revised.

### **Committee membership**

The following organizations were represented on the Technical Committee on Timber, furniture and engineered wood (RSB/TC 54) in the preparation of this standard.

CAMOSAG LTD

Cleaner Production and Climate Innovation Centre (CPCIC)

Energy Development Corporation Limited (EDCL)

GIZ

National Industrial Research and Development Agency (NIRDA)

Rwanda Inspectorate, Competition and Consumer Protection Authority (RICA)

Rwanda Transport development Agency (RTDA)

Ultimate Forest Company Ltd

University of Rwanda – College of Science and Technology (UR-CST)

Rwanda Standards Board (RSB) – Secretariat

## Introduction

Despite the Rwandan growth trend, the wood sector has not been implemented as required to produce high quality wood products and vigorous competitive market. The quality of wooden furniture is highly affected by the quality of timber, standardized production chain, quality control mechanism and grading rules. The lack of aforesaid factors results into market dominated by poor quality wooden furniture, compromised safety and unfair competition at the market.

The emerging market dynamics show that consumer's preferences have gradually shifted from furniture made by local timbers to the imported ones, which is considered as a limiting factor to the development and growth of the wood economy in Rwanda.

To ensure a positive trade balance in wood market there is a dire need to improve and ensure quality of domestic wood products.

This Standard is one of the series of standards on furniture in Rwanda. The series currently consists of the following:

RS 423-1: 2020, *Furniture — Functional sizes and Performance Requirements — Part 1: Chairs and tables for office furniture*

RS 423-2: 2020, *Furniture — Functional sizes and Performance Requirements — Part 2: Storage units*

RS 423-3: 2020, *Furniture — Functional sizes and Performance Requirements — Part 3: Chairs and tables for educational institutions*

RS 427: 2020, *Round and sawn timber — Nomenclature of timbers used in Rwanda*

DRS 433: 2019, *Furniture — Chairs and tables for home furniture — Functional sizes, strength, durability and stability for seating and tables (Under development)*

DRS 434: 2019, *Furniture — Tables — Test methods for the determination of stability, strength and durability (Under development)*

DRS 435: 2019, *Timber in joinery — General requirements (Under development)*

RS ISO 7173: 1989, *Furniture — Chairs and stools — Determination of strength and durability.*



# Furniture — Specifications for bedsteads

## 1 Scope

This Rwanda Standard specifies the basic functional sizes for bedsteads. It also includes requirements for strength and durability.

## 2 Normative references

The following documents are referred to in the text in such a way that some or all of their content constitutes requirements of this document. For dated references, only the edition cited applies. For undated references, the latest edition of the referenced document (including any amendments) applies.

RS ISO 24294, *Round and Sawn Timber — Vocabulary*

RS ISO 19833, *Furniture — Beds — Test methods for the determination of stability, strength and durability*

RS ISO 19209, *Adhesives — Classification of thermoplastic wood adhesives for non-structural applications*

RS 413, *Furniture — Quality and grading of wooden furniture*

## 3 Terms and definitions

For the purposes of this standard, the terms and definitions given in RS ISO 24294 and the following apply.

### 3.1

#### **bedstead**

framework of a bed on which the mattress and bedclothes are placed

### 3.2

#### **bunk bed**

type of bed in which one bed frame is stacked on top of another, allowing two or more beds to occupy the floor space usually required by just one

NOTE Bunk beds are commonly used in hostels and school dormitory.

### 3.3

#### **workmanship**

degree of skill with which a product is made

## 4 Types

The bedsteads covered by this standard include the following types:

- a) single bed,
- b) medium bed,
- c) double bed,
- d) queen size bed,
- e) king size bed, and
- f) bunk bed

## 5 General requirements

### 5.1 Materials

#### 5.1.1 Timber

Timber to be used for bedstead production shall be one of the renowned timber species listed in RS 427. Perishable timber species shall be accepted when such timber is treated against fungal and insect infestation with a non-leachable preservative as directed by the manufacturer and approved by the authority in charge of environment protection.

#### 5.1.2 Moisture Content

All wood used shall be dried to a moisture content between 12 % and 19 % at the time of delivery as complete assemblies. However, actual moisture content should correspond to the one expected during service.

#### 5.1.3 Defects

Lumber used for bedstead production, shall be free from decay, wane, compression failure, fungal growth, brittle heart, stains, insect attack, pitch pocket or streaks, borer holes, dead knots, splits, checks, cracks and warp such as twist, bow, spring and cup.

The lumber shall meet the permissible defects specified in clause 6 of RS 413.

#### 5.1.4 Other Materials

Other materials such as plastic, fabric, glass, metal, leather and foam may be used in combination with timber.



### 5.1.5 Adhesives

Adhesives used shall be compatible with the wood preservative applied and shall not be expired at the time of application. The adhesive used shall be one of the adhesive accepted by RS ISO 19209.

The mixing and preparation of adhesives shall follow the manufacturer's instructions.

### 5.1.6 Fittings and fasteners

Fittings such as castors, railings, knobs and handles may be made of wood, plastics or metal. Brass, stainless steel, aluminium hinges and screws may be used as fasteners.

## 5.2 Construction

### 5.2.1 General

Bedstead components shall be smooth and well planned to finished dimensions using appropriate cutting tools and free of natural defects as listed in 5.1.3.

### 5.2.2 Joints

Use of nails as joints is not recommended; instead dowels of the same species, colour and strength are preferred. Corrosion resistant screws made from stainless steel or galvanized metal may be used.

The joint type should be carefully chosen so as to enhance maximum strength. The joints shall be mortise and tenon, dowel, bridle or brace plate made of wood or metal or a combination of both.

All surfaces should be planed to a smooth finish in such way as to bring all members into contact exactly over the whole area of the joint before fasteners are applied. Joints should be fastened securely without damaging the timber.

## 5.3 Dimensions and sizes

Beds must be designed to provide support to all parts of the body in a comfortable way. Beds can be constructed with legs or without legs.

Figure 1 and Table 1 give dimensions for various categories of beds.

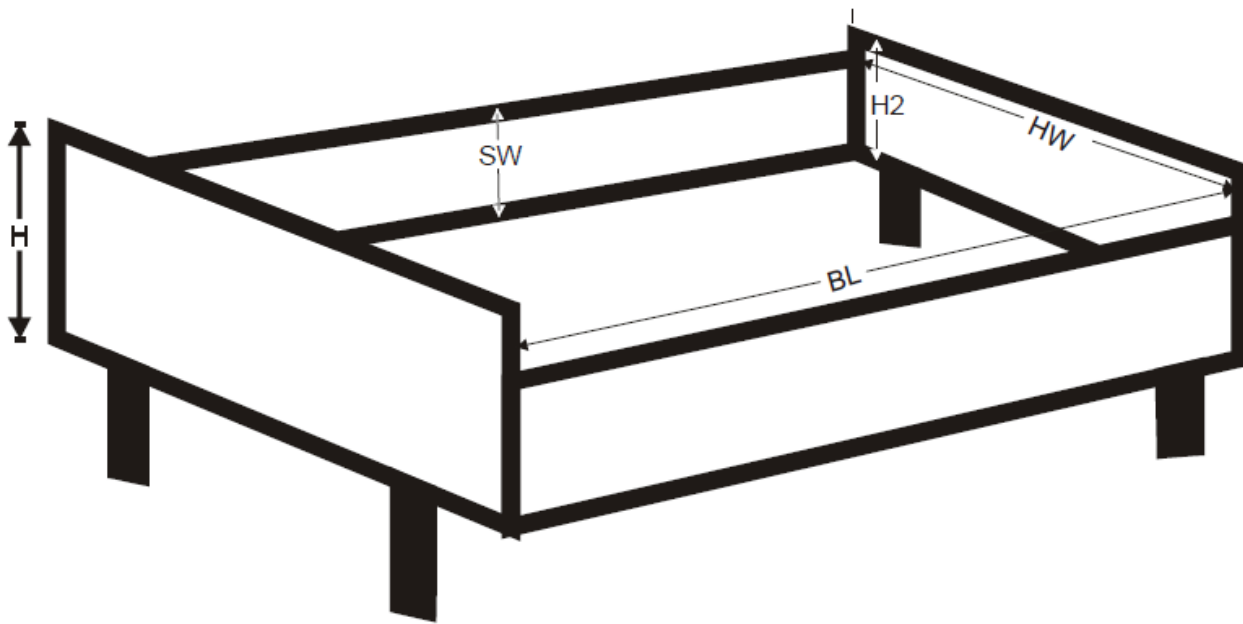

Figure 1 — Beds for domestic use

Table 1 — Dimensions for different bedsteads

Dimensions (mm)	Single	Medium	Double	Queen	King	Bunk
Minimum head/foot board height, H	140	140	140	140	140	140
Minimum width of side rails, SW,	140	140	140	140	140	140
Minimum bed slat/in-lays width, HW-5,	900	1 200	1 400	1 600	1 800	750
Minimum bed slat/in-lays length, BL,	1 950	1 950	1 950	1 950	1 950	1 950
Minimum Height between upper and lower bed base						800
NOTE Bunk bed is known as double decker						

#### 5.4 Workmanship and finishing

Exposed edges and protruding parts shall be rounded and free from sharp edges. Other materials such as reconstituted wood products, metal, glass and plastic may be used.

Such materials shall be smooth, even textured, and free from overlap and blemish. Sanding shall be done to achieve smooth surface before spraying a wood finish.

## 6 Requirements for strength and durability

### 6.1 General

Every bedstead shall be checked for good workmanship and shall be free from any defect including stain and warp.

When tested for durability in accordance with RS ISO 19833, the frame and structural fastenings shall not be damaged or malfunction; nor shall any part detach.

When tested in accordance with RS ISO 19833, the bed shall not overturn.

### **6.36.2** Test procedures for strength and durability

The requirements for strength and durability of bedsteads shall be tested in accordance with the requirements of RS ISO 19833.

## 7 Marking

All wooden bedsteads shall be marked legibly and indelibly with the name, address or recognized trade-mark, name of the product, timber species used, lot number and country of origin.

## 8 Packing for transportation

**8.1** All the component parts shall be packed after wrapping with water-proof material in such a way that no damage is caused to them during transit.

**8.2** The purchaser may require the wooden battens to be supplied in knocked down condition, in which case, the manufacturer shall prepare the components fully for quick joining and shall supply the purchaser with complete illustrated details and instructions for assembly and pack the components in wooden crates.

## Bibliography

- [1] GS 982: 2009, *Furniture — Specifications for bedsteads*
- [2] GS 983: 2009, *Furniture — Specifications of furniture components*
- [3] ISO 9098:1994, *Bunk beds for domestic use — Safety requirements and tests — Parts 1 & 2*
- [4] FDUS 1918:2018, *Furniture — Wooden beds for use with mattress — Specification*
- [5] BS EN 747 – 1: 1993, *Bunk Beds for Domestic Use*

Copy for public comments only

Copy for public comments only

---

---

Price based on 5 pages